



LITE-ON Tech. Corp.

產品承認書 (APPROVAL SHEET)

公司名稱 (Customer) : 研華股份有限公司

產品名稱 (Part Description) : SSD 固態硬碟

製造原廠 (Manufacture) : 光寶科技股份有限公司

光寶品名 (Model Name) : PZ8-CC032、PZ8-CC064

光寶料號 (P/N) :

PZ8-CC032 3Y01104005

PZ8-CC064 3Y01108005

晶片廠牌 (Chip brand) : Marvell 9188 4CH + Toshiba Flash 15nm

Density:	32/64GB	Interface:	SATA 6Gb/s
Form Factor:	2.5"	Voltage:	3.3V
Pin Count:	75pin	Firmware version :	1.00
Ambient OP Temp:	0~70°C	Ambient Non-OP Temp:	-40~+85°C

CUSTOMER APPROVAL BY

--	--	--	--

LITEON

LITE-ON Tech. Corp.

ENGINEERING SPECIFICATIONS

Product Name: PZ8-CCXXX

**LITE-ON
Confidential**



LITE-ON Tech. Corp.

Version	History	Date
1.0	First Release	20160301

LITE-ON
Confidential



LITE-ON Tech. Corp.

Table of Contents

1	Introduction	5
1.1	Overview	5
1.2	Product Specification	5
1.3	Functional Block Diagram	10
1.4	Mechanical Drawing.....	10
1.5	Architecture	11
1.6	Hot Plug Support	11
2	Pin Locations and Signal Descriptions	12
2.1	Pin Locations	12
2.2	Signal Descriptions	12
3	ATA Command Sets	14
3.1	ATA Command	14
3.2	Power Management Command Set.....	18
3.3	Security Mode Feature Set	18
3.4	SMART Command Set	18
3.5	Host Protected Area Command Set.....	19
3.6	48-Bit Address Command Set	19
3.7	Device Configuration Overlay Command Set	20
3.8	General Purpose log Command Set	20
4	SATA Command Sets.....	21
4.1	SATA Command.....	21
5	References	22
6	Terms and Acronyms	23

1 INTRODUCTION

1.1 Overview

The **PZ8-CCXXX** series 2.5" industrial grade SATA 6Gb/s Solid State Drive (SSD) delivers leading performance in an industry standard 2.5" form factor while simultaneously improving system responsiveness for mobile applications over standard rotating drive media or hard disk drives. By combining leading NAND flash memory technology with our innovative high performance firmware, LITEON delivers a SSD for native Serial Advanced Technology Attachment (SATA) hard disk drive drop-in replacement with enhanced performance, reliability, ruggedness and power savings. Since there are no rotating platters, moving heads, fragile actuators, or unnecessary delays due to spin-up time or positional seek time that can slow down the storage subsystem, significant I/O and throughput performance improvement is achieved as compared to rotating media or hard disk drives. This document describes the specifications of the **PZ8-CCXXX** series 2.5" industrial grade SATA 6Gb/s SSD in 2.5" form factors.

The **PZ8-CCXXX** series 2.5" industrial grade SATA 6Gb/s SSD primarily targets SATA based servers, fan less laptop PCs, highly rugged mobile client devices, as well as thin and light mini/sub-notebooks. Key attributes include high performance, low power, increased system responsiveness, high reliability, and enhanced ruggedness as compared to standard mobile SATA hard drives. The **PZ8-CCXXX** series 2.5" industrial grade SATA 6Gb/s SSD is available in a 2.5" form factor that is electrically, mechanically, and software compatible with existing 2.5" industrial grade Serial ATA slots and cables. Our flexible design allows interchangeability with existing mobile hard drives based on the SATA interface standard.

1.2 Product Specification

1.2.1. Form Factor: 2.5" SSD form factor

1.2.2. Capacity:

Table 1 User Addressable Sectors

Model	Unformatted capacity	Total user addressable sectors in LBA mode
PZ8-CC032	32GB	62,533,296
PZ8-CC064	64GB	125,045,424

Notes:

1.1GB=1,000,000,000 bytes and not all of the memory can be used for storage.

2.1 Sector = 512 bytes

1.2.3. Flash: Multi-Level Cell (MLC) component with Toggle-Mode

1.2.4. Band Performance

Table 2 Maximum Sustained Read and Write Bandwidth

Capacity	Access Type	MB/s
32GB	Sequential Read	Up to 150
	Sequential Write	Up to 30
64GBG	Sequential Read	Up to 300
	Sequential Write	Up to 80

Notes:

- Performance measured using CrystalDiskMark
- 2.1 MB/sec = 1,048,576 bytes/sec is used in measuring sequential performance.
If 1 MB/sec = 1,000,000 bytes/sec is used, performance values become 4.85% higher.
- Test platform: ASUS P8Z77 PRO (Windows 7 x64)
- Test by secondary drive (data drive) under SATA 6Gb/s.

1.2.5. Read and Write IOPS (IOMETER)

Table 3 Random Read/Write Input/Output Operations per Second

Capacity	Access Type	IOPS
32GB	4K Random Read	25,000
	4K Random Write	9,000
64GB	4K Random Read	48,000
	4K Random Write	21,000

Notes:

- Performance measured using IOMETER with queue depth set to 32, Crystal Disk Mark QD32
- Write cache enabled.
- Test platform: ASUS P8Z77 PRO (Windows 7 x64)
- Test by secondary drive (data drive) under SATA 6Gb/s.

1.2.6. Ready Time

Table 4 Latency Specifications

Type	Average Latency
Power on to Ready	300ms

Notes:

- Device measured form power-on to ready to receive first Media command
- Power On To Ready time assumes drive have normal shutdown process which have STANDBY IMMEDIATE command. Time varies if shutdown is not preceded by

1.2.7. Power Management

- 5V SATA
- SATA interface power management
- OS-aware hot plug/removal

1.2.8. Power Consumption

Table 5 Operating Voltage

Capacity	Description	Min	Max	Unit
32GB	Operating voltage for 5V (+/- 5%)	4.75	5.25	V
64GB	Operating voltage for 5V (+/- 5%)	4.75	5.25	V

Table 6 Power Consumption (MobileMark)

Capacity	Mode	Max	Unit
32GB	DIPM Enable	0.25	W
64GB	DIPM Enable	0.25	W

1.2.9. Temperature

Table 7 Temperature Relative Specifications

Environment	Mode	Min	Max	Unit
Ambient Temperature	Operating	0	70	°C
	Non-operating	-40	85	°C
Humidity	Operation	5	95	%
	Non-operation	5	95	%

Note: Measured without condensation

1.2.10. Compatibility

- SATA Revision 3.0 compliant
 - Compatible with SATA 1.5Gb/s, 3.0Gb/s & 6.0Gb/s interface rates
- ATA/ATAPI- 8 compliant
- SSD enhanced SMART ATA feature set
- Native Command Queuing (NCQ) command set
- TRIM supported

1.2.11. Certifications

Table 8 Device Certifications

Certification	Description
CE compliant	Indicates conformity with the essential health and safety requirements set out in European Directives Low voltage Directive and EMC Directive
UL certified	Underwriters Laboratories, Inc. Component Recognition UL60950-1
BSMI	Compliance to the Taiwan EMC standard “Limits and methods of Radio Disturbance Characteristics of Information Technology Equipment, CNS 13438 Class B”
Microsoft WHQL	Microsoft Windows Hardware Quality Labs
RoHS compliant	Restriction of Hazardous Substance Directive

1.2.12. Reliability

Table 9 Reliability specifications

Parameter	Value
Mean Time between Failure (MTBF)	> 1,500,000 hours
Power on/off cycles	50000 cycles

Notes:

- 1.MTBF is calculated based on a Part Stress Analysis. It assumes nominal voltage. With all other parameters within specified range.
- 2.Power on/off cycles is defined as power being removed from the drive, and the restored. Most host systems remove power from the drive when entering suspend and hibernate as well as on a system shutdown.

1.2.13. Shock and Vibration

Table 10 Shock and Vibration

Item	Mode	Timing/Frequency	Max
Shock	Non-operating	At 1 msec half-sine	1500G
	Non-operating	At 2 msec half-sine	1000G
Vibration	Non-operation	20~2000 Hz	16.3Grms

Notes:

- 1.Shock specifications assume that the SSD is mounted securely with the input vibration applied to the drive mounting screws. Stimulus may be applied in the X, Y or Z axis
- 2.Vibration specifications assume that the SSD is mounted securely with the input vibration applied to the drive mounting screws. Stimulus may be applied in the X, Y or Z axis. The measured specification is in root mean squared form.

1.2.14. Electromagnetic Immunity

Electromagnetic Immunity tests assume the SSD is properly installed in the representative host system. The drive operates properly without errors degradation in performance when subjected to radio frequency (RF) environments defined in the following table.

Table 11 Radio Frequency Specifications

Test	Description	Performance criteria	Reference standard
Electrostatic discharge	Contact ±4KV Air: ±8KV	A	IEC 61000-4-2:2008
Electrostatic discharge	Contact ±6KV Air: ±12KV	B	IEC 61000-4-2:2008
Electrostatic discharge	Contact ±8KV Air: ±15KV	C	IEC 61000-4-2:2008
Radiated RF immunity	80~1000MHz, 3V/m, 80% AM with 1 KHz sine 900 MHz, 3 V/m, 50% pulse modulation at 200Hz	A	IEC 61000-4-3:2008
Electrical fast transient	±1KV on AC mains ±0.5KV on external I/O	B	IEC 61000-4-4:2004 +Corr.1:2006 +Corr.2:2007
Surge immunity	±1KV differential ±2KV common, AC mains	B	IEC 61000-4-5:2005
Conducted RF immunity	150KHz~80 MHz, 3 Vrms, 80% AM with 1KHz sine	A	IEC 61000-4-6:2008
Power frequency magnetic field	50Hz, 1A/m (r.m.s.)	A	IEC 61000-4-6:2008

Notes:

1. Performance criterion A = The device shall continue to operate as intended, i.e., normal unit operation with no degradation of performance.
2. Performance criterion B = The device shall continue to operate as intended after completion of test, however, during the test, some degradation of performance is allowed as long as there is no data loss operator intervention to restore device function.
3. Performance criterion C = Temporary loss of function is allowed. Operator intervention is acceptable to restore device function.
4. Contact electrostatic discharge is applied to drive enclosure.

1.2.15. Weight: 60 g Max (with case)

1.2.16. Dimension: 100.0 x 69.85mm x 6.8 mm (L x W x H)

1.3 Functional Block Diagram

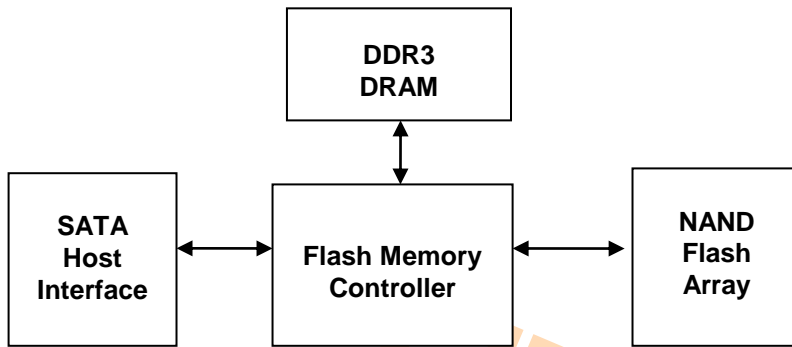

1.4 Mechanical Drawing

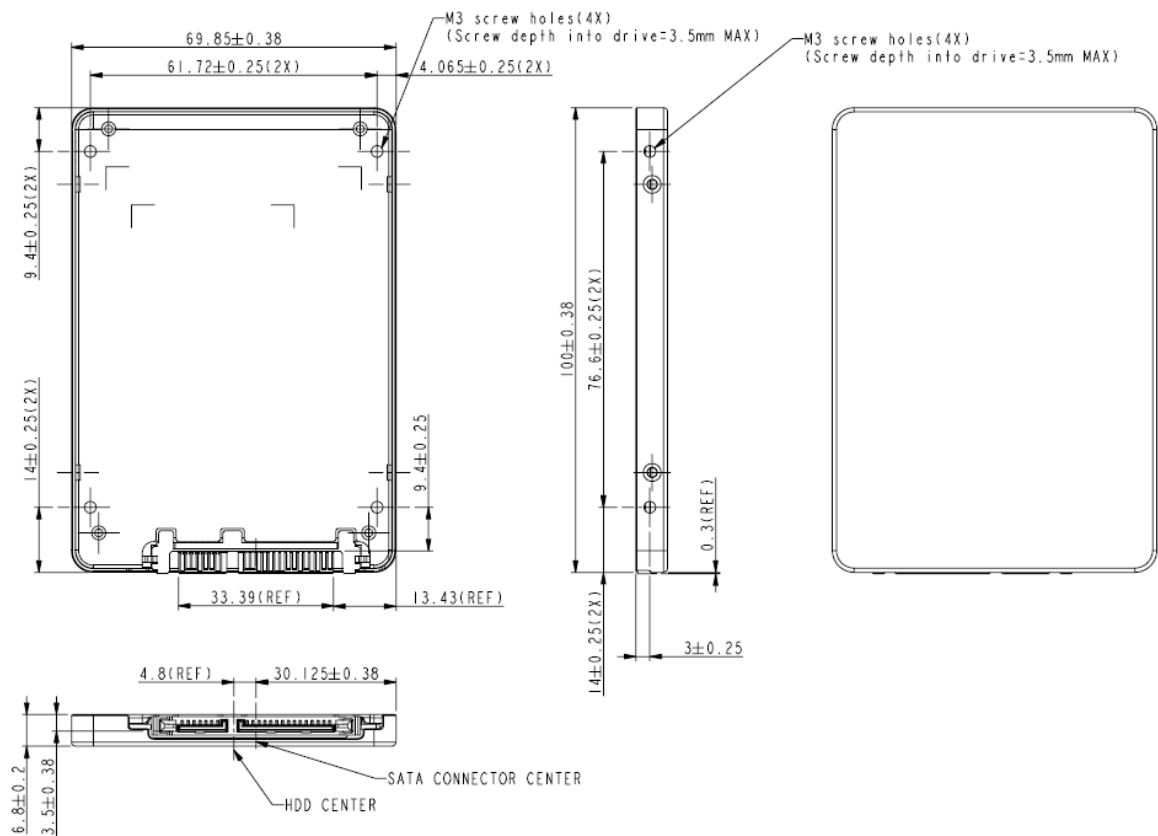

Dimension: 100.0 x 69.85mm x 6.8 mm (L x W x H)



[LITE-ON Tech. Corp.](http://www.liteon.com)

1.5 Architecture

The **PZ8-CCXXX** series 2.5" industrial grade SATA 6Gb/s Solid State Drive (SSD) utilizes a cost effective system-on-chip (SoC) design to provide a full 6Gb/s bandwidth with the host while managing multiple flash memory devices on multiple channels internally.

1.6 Hot Plug Support

Hot Plug insertion and removal are supported when the correct connector and an appropriate operating system (OS) are used as described in the SATA 3.0 Specification. This product supports asynchronous signal recovery and will establish communications with a host system without hardware device detection by issuing an unsolicited COMINIT when first mated with a powered connector.

LITE-ON
Confidential

2 PIN LOCATIONS AND SIGNAL DESCRIPTIONS

2.1 Pin Locations

The data and power connector pin locations of the **PZ8-CCXXX** series 2.5" SATA 6Gb/s SSD are as shown below.

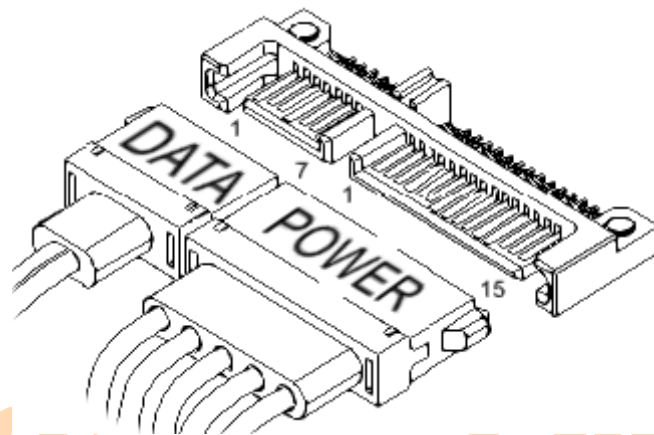

2.2 Signal Descriptions

Data Connector:

Table 12 Serial ATA Data Connector Pin Definitions

Name	Type	Description
S1	GND	
S2	A+	Differential Signal Pair A
S3	A-	
S4	GND	
S5	B-	Differential Signal Pair B
S6	B+	
S7	GND	

Power Connector:

Table 13 Serial ATA Power Connector Pin Definitions

Name	Type	Description
P1	Retired	No Use
P2	Retired	No Use
P3	Retired	No Use
P4	GND	
P5	GND	
P6	GND	
P7	V5	5V Power, Pre-charge
P8	V5	5V Power
P9	V5	5V Power
P10	GND	
P11	DAS	Device Activity Signal
P12	GND	
P13	V12	No Use
P14	V12	No Use
P15	V12	No Use

Note:

1. All pins are in a single row, with a 1.27mm (0.05") pitch
2. The mating sequence is
 - The ground pins P4-P6, P10, P12 and the 5V power pin P7
 - The signal pins and the rest of the 5V power pins P8-P9
3. Ground connectors P4 and P12 may contact before the other 1st mate pins in both the power and signal connectors to discharge ESD in a suitably configured backplane connector.
4. Power pins P7, P8 and P9 are internally connected to one another within the device.
5. The host may ground P11 if it is not used for Device Activity Signal (DAS)
6. Pins P13, P14, P15 are connected together, although they are not connected internally to the device.

3 ATA COMMAND SETS

3.1 ATA Command

The SSD supports all the mandatory ATA commands defined in the ATA/ATAPI-8 specification.

3.1.1 ATA General Feature Command Set

The SSD supports the ATA General feature Command set (non-packet), which consists of the following events.

- EXECUTE DEVICE DIAGNOSTIC
- FLUSH CACHE
- IDENTIFY DEVICE
- READ DMA
- READ DMA WITHOUT RETRIES
- READ SECTOR(S)
- READ SECTORS(S) WITHOUT RETRIES
- READ VERIFY SECTORS(S)
- READ VERIFY SECTORS(S) WITHOUT RETRIES
- SEEK
- SET FEATURES
- WRITE DMA
- WRITE DMA WITHOUT RETRIES
- WRITE SECTOR(S)
- WRITE SECTOR(S) WITHOUT RETRY
- READ MULTIPLE
- SET MULTIPLE MODE
- WRITE MULTIPLE
- INITIALIZE DEVICE PARAMETERS
- DATA SET MANAGEMENT

The SSD supports all the following optional commands.

- READ BUFFER
- WRITE BUFFER
- DOWNLOAD MICROCODE

3.1.2 Identify Device Data

The following table details the sector data returned after issuing an IDENTIFY DEVICE command.

Table 14 Returned Sector Data

Word	F=Fixed V=Variable X=Both	Default Value	Description
0	F	0040h	General configuration bit-significant information
1	F	3FFFh	Obsolete-Number of logical cylinders (16,383)
2	F	C837h	Specific configuration
3	F	0010h	Obsolete-Number of logical heads (16)
4-5	F	0000h	Retired
6	F	003Fh	Obsolete-Number of logical sectors per logical track (63)
7-8	F	0000h	Reserved for assignment by the Compact Flash Association
9	F	0000h	Retired
10-19	V	Var.	Serial number (20 ASCII characters)
20-22	F	0000h	Retired / Obsolete
23-26	V	Var.	Firmware revision (8 ASCII characters)
27-46	V	Var.	Model number
47	F	8010h	7:0 – Maximum number of sectors transferred per interrupt on multiple commands
48	F	4000h	Trusted Computing feature set options, bit14 should be 1
49	F	2F00h	Capabilities
50	F	4000h	Capabilities
51-52	F	0000h	Obsolete
53	F	0007h	Words 88 and 70:64 valid
54	V	Var.	Obsolete - Number of logical cylinders (16,383)
55	V	Var.	Obsolete - Number of logical heads (16)
56	V	Var.	Obsolete - Number of logical sectors per logical track (63)
57-58	V	Var.	Capacity(Cylinders*heads*sectors)
59	V	0101h	Number of sectors transferred per interrupt on multiple commands
60-61	V	250,069,680 (128GB)	Total number of user addressable logical sectors for 28-bit commands (DWord)
		500,118,192 (256GB)	
		1,000,215,216 (512GB)	
62	F	0000h	Obsolete
63	V	0007h	Multi-word DMA modes supported/selected
64	F	0003h	PIO modes supported
65	F	0078h	Minimum multiword DMA transfer cycle time per word
66	F	0078h	Manufacture's recommended multiword DMA transfer cycle time
67	F	0078h	Minimum PIO transfer cycle time without flow control
68	F	0078h	Minimum PIO transfer cycle time with tORDY flow control



LITE-ON Tech. Corp.

Word	F=Fixed V=Variable X=Both	Default Value	Description
69-70	F	0000h	Reserved(for future command overlap and queuing)
71-74	F	0000h	Reserved for the IDENTIFY packet DEVICE command
75	F	001Fh	4:0 Maximum Queue depth-1=31
76	V	070Eh	Serial ATA capabilities
77	V	Var.	Reserved for Serial ATA
78	V	004Ch	Serial ATA features supported
79	V	0040h	Serial ATA features enabled
80	F	01FEh	Major Version Number
81	F	0021h	Minor Version Number
82	F	346Bh	Commands and feature sets supported
83	F	7D01h	Commands and feature sets supported
84	F	4023h	Commands and feature sets supported
85	V	3469h	Commands and feature sets supported or enabled
86	V	BC01h	Commands and feature sets supported or enabled
87	F	4023h	Commands and feature sets supported or enabled
88	V	407Fh	Ultra DMA modes
89	F	0003h	Time required for security erase unit completion
90	F	0003h	Time required for enhanced security erase completion
91	F	0000h	Current advanced power management value
92	V	Var.	Master Password Identifier
93	V	0000h	Hardware reset result. The contents of bits (12:0) of this word shall change only during the execution of a hardware reset.
94	F	0000h	Current AAM value
95	F	0000h	Stream Minimum Request Size
96	F	0000h	Streaming Transfer Time - DMA
97	F	0000h	Streaming Access Latency - DMA and PIO
98-99	F	0000h	Streaming Performance Granularity
100-103	V	250,069,680 (128GB)	Maximum user LBA for 48-bit Address feature set
		500,118,192 (256GB)	
		1,000,215,216 (512GB)	
104	F	0000h	Streaming Transfer Time - PIO
105	F	0008h	Maximum number of 512-byte blocks per DATA SET MANAGEMENT command
106	F	6003h	Physical sector size/logical sector size
107	F	0000h	Inter-seek delay for ISO-7779 acoustic testing in microseconds
108-111	V	0000h 0000h 0000h 0000h	World wide name
112-115	F	0000h	Reserved for word wide name extension to 128 bits
116	F	0000h	Reserved for TLC
117-118	F	0000h	Words per logical sector
119	F	4010h	Commands and feature sets supported
120	F	4010h	Commands and feature sets supported or enabled



LITE-ON Tech. Corp.

Word	F=Fixed V=Variable X=Both	Default Value	Description
121-126	F	0000h	Reserved for expanded supported and enabled settings
127	F	0000h	Removable Media Status Notification feature set support
128	V	0021h	Security status
129-159	F	0000h	Vendor specific
160	F	0000h	Compact Flash Association (CFA) power mode 1
161-167	F	0000h	Reserved for the CompactFlash Association
168	F	0000h	
169	F	0001h	DATA SET MANAGEMENT command is supported
170-173	V	Var.	Additional Product Identifier (ATA String)
174-175	F	0000h	Reserved
176-205	F	0000h	Current media serial number (ATA string)
206	F	003Dh	SCT Command Transport
207-208	F	0000h	Reserved
209	F	4000h	Alignment of logical blocks within a physical block
210-211	F	0000h	Write-Read-Verify Sector Count Mode 3 (DWord)
212-213	F	0000h	Write-Read-Verify Sector Count Mode 2 (DWord)
214	F	0000h	NV Cache Capabilities
215-216	F	0000h	NV Cache Size in Logical Blocks (DWord)
217	F	0001h	Nominal media rotation rate
218	F	0000h	Reserved
219	F	0000h	NV Cache Options
220	F	0000h	7:0 Write-Read-Verify feature set current mode
221	F	0000h	Reserved
222	F	1075h	Transport major version number
223	F	0000h	Transport minor version number
224-229	F	0000h	Reserved
230-233	F	0000h	Extended Number of User Addressable Sectors (QWord)
234	F	0000h	Minimum number of 512-byte data blocks per DOWNLOAD MICROCODE command for mode 03h
235	F	0000h	Minimum number of 512-byte data blocks per DOWNLOAD MICROCODE command for mode 03h
236-254	F	0000h	Reserved
255	V	Var.	Integrity word

Note:

- 1.F=Fixed. The content of the word is fixed and does not change for removable media devices, these values may change when media is Removed or changed.
- 2.V=Variable. The state of at least one bit in a word is variable and may change depending on the state of the device or the commands executed by the device.
- 3.X=F or V. The content of the word may be fixed or variable.

3.2 Power Management Command Set

The SSD supports the power management command set, which consists of the following events.

- CHECK POWER MODE
- IDLE
- IDLE IMMEDIATE
- SLEEP
- STANDBY
- STANDBY IMMEDIATE

3.3 Security Mode Feature Set

The SSD supports the Security Mode command set, which consist of the following events.

- SECURITY SET PASSWORD
- SECURITY UNLOCK
- SECURITY ERASE PREPARE
- SECURITY ERASE UNIT
- SECURITY FREEZE LOCK
- SECURITY DISABLE PASSWORD

3.4 SMART Command Set

The SSD supports the SMART command set, which consist of the following events.

- SMART ENABLE OPERATIONS
- SMART DISABLE OPERATIONS
- SMART ENABLE/DISABLE AUTOSAVE
- SMART RETURN STATUS

The SSD supports the following optional commands.

- SMART EXECUTE OFF-LINE IMMEDIATE
- SMART READ DATA
- SMART READ LOG
- SMART WRITE LOG

The table below lists the SMART commands.

Table 15 SMART commands

Subcommand	Code	LBA Low value
SMART ATTRIBUTE VALUES (READ DATA)	D0h	
READ ATTRIBUTE THRESHOLDS	D1h	
ENABLE/DISABLE ATTRIBUTE AUTOSAVE	D2h	
SAVE ATTRIBUTE VALUES	D3h	
EXECUTE OFF-LINE IMMEDIATE	D4h	
EXECUTE SMART OFF-LINE ROUTINE		00h
EXECUTE SMART SHORT SELF-TEST ROUTINE (OFFLINE)		01h
EXECUTE SMART EXTENDED SELF-TEST ROUTINE (OFFLINE)		02h
ABORT OFF-LINE ROUTINE		7Fh
EXECUTE SMART SHORT SELF-TEST ROUTINE (CAPTIVE)		81h
EXECUTE SMART EXTENDED SELF-TEST ROUTINE (CAPTIVE)		82h
READ LOG SECTOR	D5h	
WRITE LOG SECTOR	D6h	
ENABLE SMART OPERATIONS	D8h	
DISABLE SMART OPERATIONS	D9h	
RETURN SMART STATUS	DAh	
Enable/Disable Automatic OFFLINE	DBh	

3.5 Host Protected Area Command Set

The SSD supports the Host Protected Area command set which consists of the following events.

- READ NATIVE MAX ADDRESS
- SET MAX ADDRESS
- READ NATIVE MAX ADDRESS EXT
- SET MAX ADDRESS EXT

The SSD supports the following optional commands.

- SET MAX SET PASSWORD
- SET MAX LOCK
- SET MAX FREEZE LOCK
- SET MAX UNLOCK

3.6 48-Bit Address Command Set

The SSD supports the Host Protected Area command set, which consists of the following events.

- FLUSH CACHE EXT
- READ DMA EXT
- READ NATIVE MAX ADDRESS EXT
- READ SECTOR(S) EXT
- READ VERIFY SECTOR(S) EXT
- READ MULTIPLE EXT

- SET MAX ADDRESS EXT
- WRITE DMA EXT
- WRITE MULTIPLE EXT
- WRITE MULTIPLE FUA EXT
- WRITE SECTOR(S) EXT

3.7 Device Configuration Overlay Command Set

The SSD supports the Device configuration Overlay command set, which consists of the following events.

- DEVICE CONFIGURATION FREEZE LOCK
- DEVICE CONFIGURATION IDENTITY
- DEVICE CONFIGURATION RESTORE
- DEVICE CONFIGURATION SET

3.8 General Purpose log Command Set

The SSD supports the general purpose log command set, which consists of the following events.

- READ LOG EXT
- WRITE LOG EXT

4 SATA COMMAND SETS

4.1 SATA Command

The SATA 3.0 Specification is a super set of the ATA/ATAPI-8 specification with regard to supported commands. The SSD supports the following features which are unique to the SATA 3.0 Specification.

4.1.1. Software Settings Preservation

The SSD supports the SET FEATURES parameter to enable/disable the preservation of software settings.

4.1.2. Native Command Queuing

The SSD supports the Native Command Queuing (NCQ) command set, which includes the following events.

- READ FPDMA QUEUED
- WRITE FPDMA QUEUED

Note: with a maximum queue depth equal to 32

5 REFERENCES

This document references standards defined by a variety of organizations as listed below.

Table 16 Standards References

Date	Title	Location
Dec 2008	VCCI	http://www.vcci.or.jp/vcci_e/general/join/index.html
July 2007	ROHS	Search for material description datasheet at http://intel.pcnalert.com
July 2007	SFF-8144, 1.8" drive form factor	http://www.sffcommittee.org
February 2007	Serial ATA Revision 2.6	http://www.sata-io.org
May 2006	SFF-8223, 2.5" Drive w/Serial Attachment Connector	http://www.sffcommittee.org
May 2005	SFF-8201, 2.5" drive form factor	http://www.sffcommittee.org
April 2004	ATA-7 Spec. Volume 1	http://www.t13.org/
Aug. 2009	ATA-8 Spec. Rev 2	http://www.t13.org/
2008	International Electro Technical Commission EB61000 4-2 Personnel Electrostatic Discharge Immunity	http://www.iec.ch
2008	4-3 Electromagnetic compatibility (EMC)	
2004	4-4 Electromagnetic compatibility (EMC)	
2005	4-5 Electromagnetic compatibility (EMC)	
2008	4-6 Electromagnetic compatibility (EMC)	
2008	4-11 (Voltage variations)	
2004	ENV 50204 (Radiated electromagnetic field from digital radio telephones)	http://www.iec.ch

6 TERMS AND ACRONYMS

This document incorporates many industry and device specific words use the following list to define a variety of terms and acronyms.

Table 17 Glossary of Terms and Acronyms

Term	Definition
ATA	Advanced Technology Attachment
ATAPI	Advanced Technology Attachment Packet Interface
DIPM	Device Initiated Power Management The ability of the device to request SATA link power state changes
DMA	Direct Memory Access
DRAM	Dynamic Random Access Memory
GB	Giga-byte defined as 1×10^9 bytes
Hot Plug	A term used to describe the removal or insertion of a SATA hard drive when the system is powered on
IOPS	Input output operations per second
LBA	Logical Block Address
MB	Mega-bytes defined as 1×10^6 bytes
MTBF	Mean time between failure
NCQ	Native Command Queuing The ability of the SATA hard drive to re-order commands in order to maximize the efficiency of gathering data from the platters
NOP	No operation
OS	Operation System
SATA	Serial ATA
SMART	Self-Monitoring, Analysis and reporting Technology An open standard for developing hard drive and software systems that automatically monitors a hard drive's health and reports potential problems
SSD	Solid State Drive
WHQL	Microsoft* Windows Hardware Quality Labs
Write Cache	A memory device within a hard drive, which is allocated for the temporary storage of data before that data is copied to its permanent storage location
VCCI	Voluntary Control Council for Interface